

TOORX
FITNESS IN MOTION

INSTRUCTION



WBX85



Dansk

Cod : GRLDTOORXWBX85

Rev : 00

Ed : 07/18

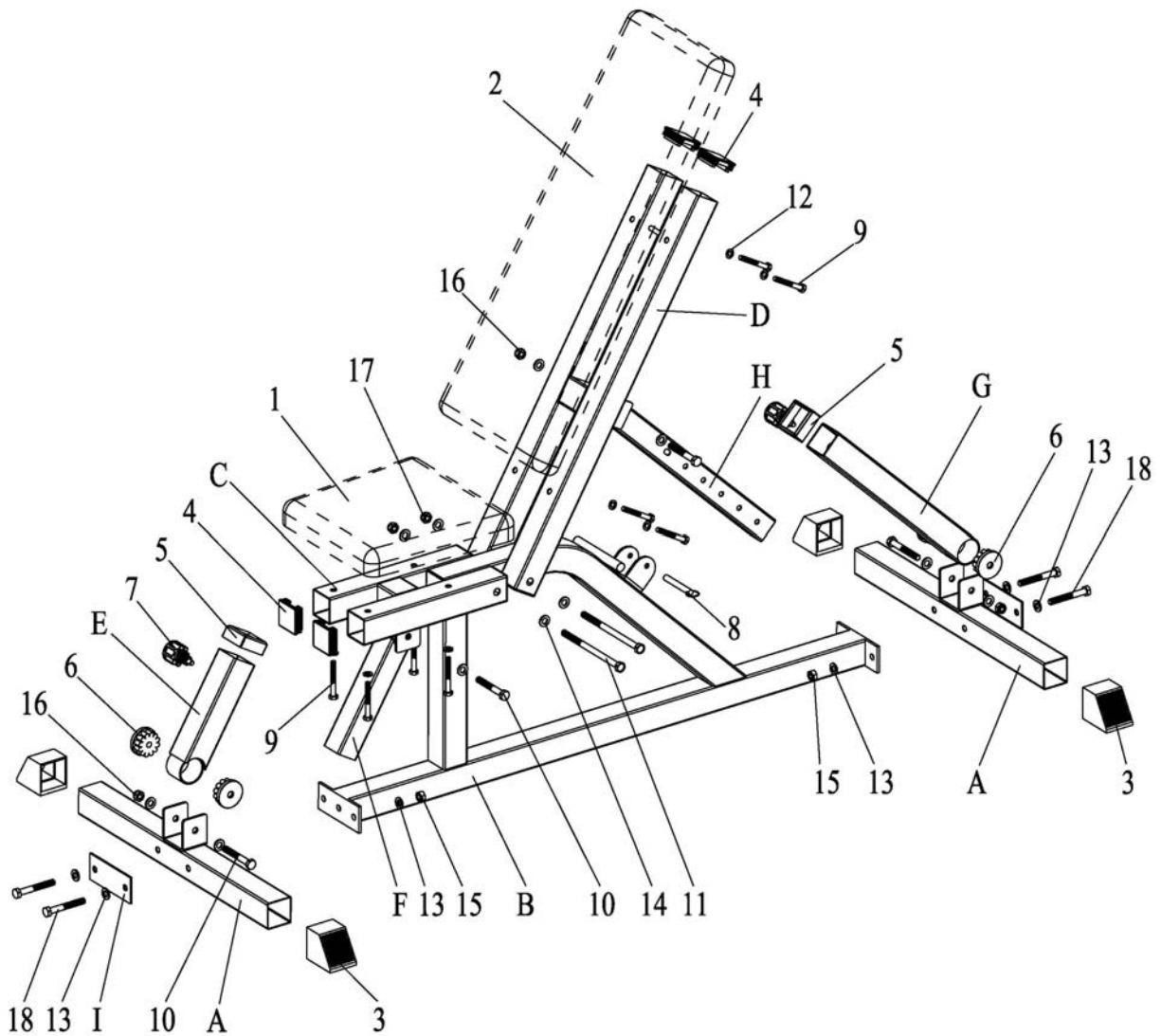

PARTS LIST

NUMBER	DESCRIPTION	QUANTITY
A	BASE	2
B	MAIN FRAME	1
C	SEAT PAD SUPPORT	1
D	BACKREST PAD SUPPORT	1
E	FRONT ADJUSTMENT HOUSING	1
F	FRONT ADJUSTMENT TUBE	1
G	BACK ADJUSTMENT HOUSING	1
H	BACK ADJUSTMENT TUBE	1
I	JOINT PLATE	2

1	SEAT PAD	1
2	BACKREST PAD	1
3	SQUARE END CAP	4
4	SQUARE CAP	9
5	PLASTIC ADAPTER 50*45	2
6	PLASTIC BUSHING 50*10	8
7	FAST PIN	2
8	PIN	1
9	BOLT M8*65	8
10	BOLT M10*90	4
11	BOLT M12*170	2
12	WASHER 8	8
13	WASHER 10	16
14	WASHER 12	4
15	NUT M10	4
16	LOCK NUT M10	4
17	LOCK NUT M12	2
18	BOLT M10*75	4

STEP 01

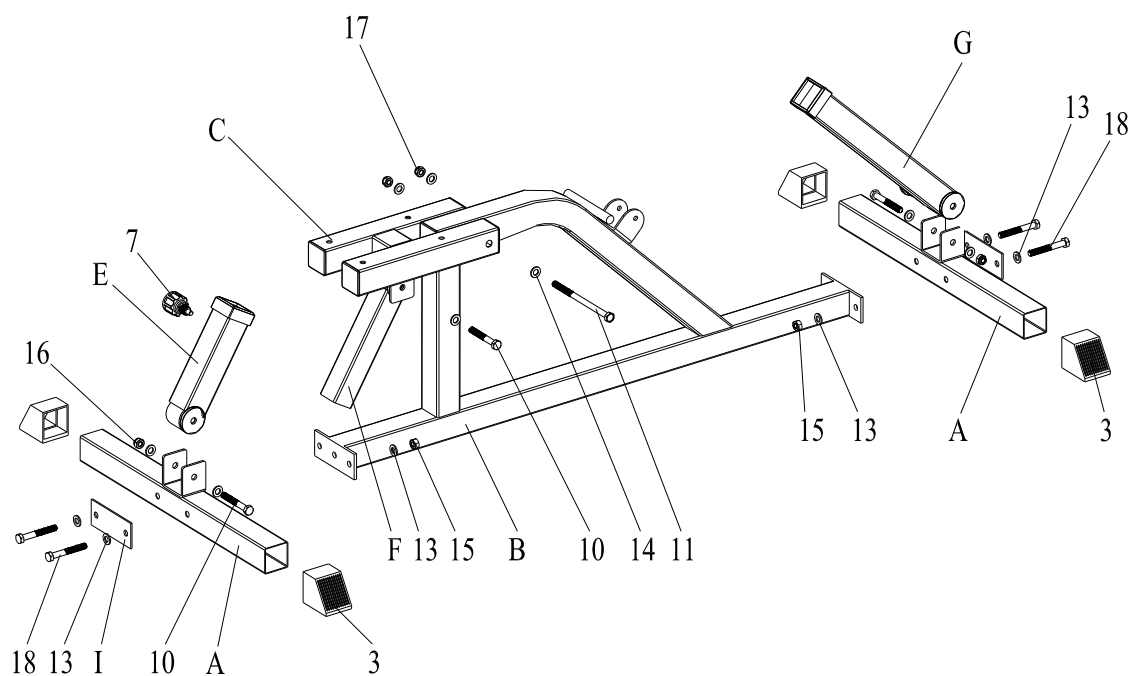

1. Fastgør A til B med I, 18, 13 og 15, og skub derefter 3 på A.
2. Fastgør E til A med 10, 13 og 16.
3. Fastgør C til E med 7.
4. Fastgør F til C med 10, 13 og 16.
5. Fastgør C til B med 11, 14 og 17, og fastgør derefter F til E med 7.
6. Fastgør G til A med 10, 13 og 16.



GARLANDO SPA
Via Regione Piemonte, 32 - Zona Industriale D1
15068 - Pozzolo Formigaro (AL) - Italy
www.toorx.it - info@toorx.it